



## User Manual

Read this manual before using machine to avoid serious injury and damage

# 50110CC-WHD 10" Bench Top Jointer

*with Spiral Style Cutterhead 4-Sided Carbide Inserts  
and Cast Iron W/Fence Support*

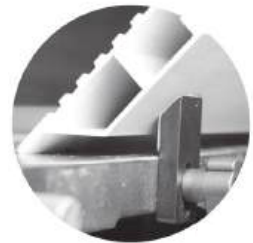

For technical support, email [techservices@wahudatools.com](mailto:techservices@wahudatools.com) or call 877-568-8879

VER 08.07.23

# TABLE OF CONTENTS

## INTRODUCTION

SECTION 1	Warranty	3
SECTION 2	Product Specifications	4
SECTION 3	Feature Identification	4
SECTION 4	General Safety	5
SECTION 5	Product Safety	8
SECTION 6	Grounding Instructions	10
SECTION 7	Unpacking & Inventory	12
SECTION 8	In The Box	13
SECTION 9	Assembly & Adjustments	15
SECTION 10	Cleaning Spiral Cutterhead & Tips	22
SECTION 11	Operations	24
SECTION 12	Maintenance	29
SECTION 13	Troubleshooting Guide	34
SECTION 14	Parts Diagram & List	44

## INTRODUCTION

This user manual is intended for use by anyone working with this machine. It should be kept available for immediate reference so that all operations can be performed with maximum efficiency and safety. Do not attempt to perform maintenance or operate this machine until you have read and understand the information contained in this manual. The drawings, illustrations, photographs, and specifications in this user manual represent your machine at time of print. However, changes may be made to your machine or this manual at any time with no obligation to WAHUDA.

# WARRANTY

## 2 YEAR LIMITED WARRANTY

WAHUDA warrants its machinery to be free of defects in workmanship and materials for a period of two (2) years from the date of the original purchase by the original owner. This warranty applies to products sold in United States only. The warranty does not apply to any product used for professional or commercial production purposes nor for industrial or educational applications. Such cases are covered by our 1 year Limited Warranty with the Conditions and Exceptions.

Warranty does not include failures, breakage or defects deemed after inspection by an Authorized Service Center or our agent to have been directly or indirectly caused by or resulting from improper use, lack of or improper maintenance, misuse or abuse, negligence, accidents, damage in handling or transport, or normal wear and tear of any part or component. Examples are consumables such as inserts and knives or wear items like drive belts, bearings or brushes. Additionally, warranty is void if repairs or alterations are made to the machine by an unauthorized service center without the direct consent of WAHUDA.

To file a claim of warranty, call toll free 877-568-8879 or email [techservices@wahudatools.com](mailto:techservices@wahudatools.com) . Warranty applies to the original buyer only and cannot be transferred. Your machines date of purchase and serial number have already been registered with WAHUDA when shipped. If you purchased your machine from one of our authorized dealers, please go online at [www.wahudatools.com](http://www.wahudatools.com) and register your machine online. Thus, you will only need to provide your full name when contacting WAHUDA.

The defective units should be returned Freight prepaid to WAHUDA's Authorized Service Center for inspection. If the warranty claim is considered to be invalid due to exclusions listed above, WAHUDA will at your direction dispose of or return the product. In the event you choose to have the product returned you will be responsible for the handling and shipping cost of the return.

WAHUDA furnishes the above warranties in lieu of all other warranties, express or implied. WAHUDA shall not be liable for any special, indirect, incidental, punitive or consequential damages, including without limitation to loss of profits arising from or related to the warranty, the breach of any agreement or warranty, or the operation or use of its machinery, including without limitation damages arising from damage to fixtures, tools, equipment, parts or materials, direct or indirect loss caused by any other part, loss of revenue or profits, financing or interest charges, and claims by and third person, whether or not notice of such possible damages has been given to WAHUDA. Not Responsible for damages of any kind for any delay by or failure of WAHUDA to perform its obligations under this agreement or claims made a subject of a legal proceeding against WAHUDA more than one (1) year after such cause of action first arose.

The validity, construction and performance of this Warranty and any sale of machinery by WAHUDA shall be governed by the law of the State of Tennessee, without regard to conflicts of law's provisions of any jurisdiction. Any action related in any way to any alleged or actual offer, acceptance or sale by WAHUDA or any claim related to the performance of and agreement including without limitation this Warranty, shall take place in the federal or state courts in Shelby County, Tennessee.

WAHUDA reserves the right to change the specifications of its machines without prior notice.

## PRODUCT SPECIFICATIONS

Cutterhead speed RPM	12,000
Motor RPM	19000+/-10% (No Load)
Cutterhead diameter	2"
Max width capacity	10"
Max depth of cut	1/8"
Cutter inserts qty	20
Motor power input	120 V, 60 Hz, AC Only, 12 Amp
Fence Size Overall	4 3/8" x 24"
Tables (Overall measurements)	10" x 33.5"
Tables (Overall with extension support)	10" x 53.5"
Shipping Weight	82 lbs
Net Weight	73.4 lbs
Shipping Dimensions	36 5/8" L x 17" W x 13 3/8" H
Machine Length	53.5"
Machine Depth with Fence	22"
Machine Height with Fence	13 1/4"

## FEATURE IDENTIFICATION

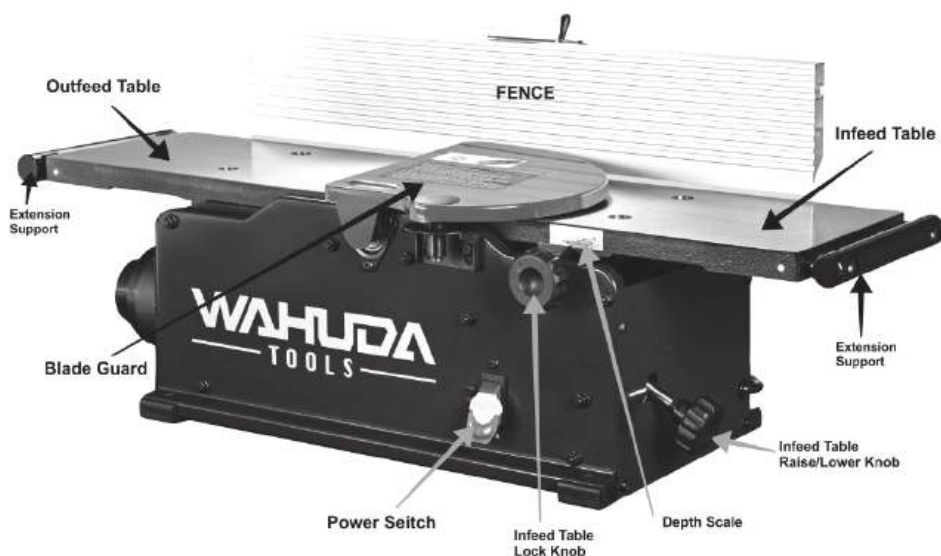

## GENERAL SAFETY

**NOTE:** The **WARNING!** and **CAUTION!** symbols indicate a potentially hazardous situation which, if not avoided, COULD result in death or serious injury. READ THIS MANUAL completely before assembling and operating this machine.

**WARNING!** TO AVOID serious injury, death, or damage to the machine, please read, understand, and follow, all Safety and Operating Instructions before assembling and operating this machine. This manual is not totally comprehensive. It does not and cannot convey every possible safety and operational problem which may arise while using this machine. The manual will cover many of the basic and specific safety procedures needed in an industrial environment.

All federal and state laws, and any regulations having jurisdiction covering the safety requirements for use of this machine, take precedence over the statements in this manual. Users of this machine must adhere to all such regulations.

**WARNING!** Exposure to the dust created by power sanding, sawing, grinding, drilling and other construction activities may cause serious and permanent respiratory or other injury, including silicosis (a serious lung disease), cancer, and death. Avoid breathing the dust, and avoid prolonged contact with dust. The dust may contain chemicals known to the State of California to cause cancer, birth defects or other reproductive harm.

Some examples of these chemicals are:

- Lead from lead-based paints.
- Crystalline silica from bricks, cement and other masonry products.
- Arsenic and chromium from chemically-treated lumber.

Always operate tool in well ventilated area and provide for proper dust removal. Use a dust collection system along with an air filtration system whenever possible. Always use properly fitting NIOSH/OSHA approved respiratory protection appropriate for the dust exposure, and wash exposed areas with soap and water.

**WARNING!** ALWAYS wear eye protection. Any machine can throw debris into the eyes during operations, which could cause severe and permanent eye damage. Everyday eyeglasses are NOT safety glasses. ALWAYS wear Safety Goggles (that comply with ANSI standard Z87.1) when operating power tools.

**WARNING!** ALWAYS wear hearing protection. Plain cotton is not an acceptable protective device. Hearing equipment should comply with ANSI S3.19 Standards.

**WARNING!** ALWAYS wear a NIOSH/OSHA approved dust mask to prevent inhaling dangerous dust or airborne particles.

## GENERAL SAFETY (cont.)

ALWAYS keep the work area clean, well lit, and organized. DO NOT work in an area that has slippery floor surfaces from debris, grease, and wax.

**CAUTION!** ALWAYS unplug the machine from the electrical receptacle when making adjustments, changing parts or performing any maintenance.

AVOID ACCIDENTAL STARTING. Make sure that the power switch is in the “OFF” position before plugging in the power cord to the electrical receptacle.

**WARNING!** AVOID a dangerous working environment. DO NOT use electrical tools in a damp environment or expose them to rain or moisture.

**WARNING!** CHILDPROOF THE WORKSHOP AREA by removing switch keys, unplugging tools from the electrical receptacles, and using padlocks.

**CAUTION!** DO NOT use electrical tools in the presence of flammable liquids or gasses.

DO NOT FORCE the machine to perform an operation for which it was not designed. It will do a safer and higher quality job by only performing operations for which the machine was intended.

**WARNING!** DO NOT stand on a machine. Serious injury could result if it tips over or you accidentally contact any moving part.

DO NOT store anything above or near the machine.

**WARNING!** DO NOT operate any machine or tool if under the influence of drugs, alcohol, or medication.

EACH AND EVERY time, check for damaged parts prior to using any machine. Carefully check all guards to see that they operate properly, are not damaged, and perform their intended functions.

Check for alignment, binding or breakage of all moving parts. Any guard or other part that is damaged should be immediately repaired or replaced.

**WARNING!** Ground all machines. If any machine is supplied with a 3-prong plug, it must be plugged into a 3-contact electrical receptacle. The third prong is used to ground the tool and provide protection against accidental electric shock. DO NOT remove the third prong.

**CAUTION!** Keep visitors and children away from any machine. DO NOT permit people to be in the immediate work area, especially when the machine is operating.

## GENERAL SAFETY (cont.)

KEEP protective guards in place and in working order.

**CAUTION!** MAINTAIN your balance. DO NOT extend yourself over the tool. Wear oil resistant rubber soled shoes. Keep floor clear of debris, grease, and wax.

MAINTAIN all machines with care. ALWAYS KEEP machine clean and in good working order. KEEP all blades and tool bits sharp.

NEVER leave a machine running, unattended. Turn the power switch to the OFF position. DO NOT leave the machine until it has come to a complete stop.

REMOVE ALL MAINTENANCE TOOLS from the immediate area prior to turning the machine ON.

**WARNING!** STAY ALERT, watch what you are doing, and use common sense when operating any machine. DO NOT operate any machine tool while tired or under the influence of drugs, alcohol, or medication. A moment of inattention while operating power tools may result in serious personal injury.

**WARNING!** USE ONLY recommended accessories. Use of incorrect or improper accessories could cause serious injury to the operator and cause damage to the machine. If in doubt, DO NOT use it.

THE USE of extension cords is not recommended for 230V equipment. It is better to arrange the placement of your equipment and the installed wiring to eliminate the need for an extension cord. If an extension cord is necessary, refer to the chart in the Grounding Instructions section to determine the minimum gauge for the extension cord. The extension cord must also contain a ground wire and plug pin.

**CAUTION!** Wear proper clothing, DO NOT wear loose clothing, gloves, neckties, or jewelry. These items can get caught in the machine during operations and pull the operator into the moving parts. Users must wear a protective cover on their hair, if the hair is long, to prevent it from contacting any moving parts.

SAVE these instructions and refer to them frequently and use them to instruct other users.

**NOTE:** Information regarding the safe and proper operation of this tool is also available from the following sources:

Power Tool Institute  
1300 Summer Avenue  
Cleveland, OH 44115-2851  
[www.powertoolinstitute.org](http://www.powertoolinstitute.org)

American National Standards Institute  
23 West 43<sup>rd</sup> Street, 4<sup>th</sup> Floor  
New York, NY 10036  
[www.ansi.org](http://www.ansi.org)

National Safety Council  
1121 Spring Lake Drive  
Itasca, IL 60143-3201

ANSI 01.1 Safety Requirements for  
Woodworking Machines and the  
U.S. Department of Labor Relations  
[www.osha.gov](http://www.osha.gov)

## PRODUCT SAFETY

1. Serious personal injury may occur if normal safety precautions are overlooked or ignored. Accidents are frequently caused by lack of familiarity or failure to pay attention. Obtain advice from supervisor, instructor, or another qualified individual who is familiar with this machine and its operations.
2. Every work area is different. Always consider safety first, as it applies to your work area. Use this machine with respect and caution. Failure to do so could result in serious personal injury and damage to the machine.
3. Prevent electrical shock. Follow all electrical and safety codes, including the National Electrical Code (NEC) and the Occupational Safety and Health Regulations (OSHA). All electrical connections and wiring should be made by qualified personnel only
4. **WARNING!** TO REDUCE the risk of electrical shock. DO NOT use this machine outdoors. DO NOT expose to rain. Store indoors in a dry area.
5. STOP using this machine, if at any time you experience difficulties in performing any operation. Contact your supervisor, instructor or machine service center immediately.
6. Safety decals are on this machine to warn and direct you to how to protector yourself or visitors from personal injury. These decals MUST be maintained so that they are legible. REPLACE decals that are not legible.
7. DO NOT leave the unit plugged into the electrical outlet. Unplug the unit from the outlet when not in use and before servicing, performing maintenance tasks, or cleaning.
8. **WARNING!** DO NOT handle the plug or jointer with wet hands
9. USE only accessories as described in this manual and recommended by WAHUDA.
10. DO NOT pull the jointer by the power cord. NEVER allow the power cord to come in contact with sharp edges, hot surfaces, oil or grease.
11. ALWAYS turn the power switch "OFF" before unplugging the jointer. DO NOT unplug the jointer by pulling on the power cord. ALWAYS grasp the plug, not the cord.
12. REPLACE a damaged cord immediately. DO NOT use a damaged cord or plug.
13. DO NOT use the jointer as a toy. DO NOT use near or around children.



## PRODUCT SAFETY (cont.)

14. ENSURE that the machine sits firmly before using. If the machine wobbles or is unstable, correct the problem by attaching to a bench top prior to operation.
15. This machine is designed to process wood ONLY.
16. **WARNING!** NEVER position fingers or thumbs near the cutterhead.
17. Long pieces of stock should ALWAYS be supported with some type of fixture.
18. DO NOT operate jointer with dull or damaged blades.
19. MAKE CERTAIN that the jointer is properly adjusted prior to use.
20. DO NOT try and remove excessive amounts of wood in one single pass.
21. INSPECT all stock before beginning operations ensuring that there are no foreign objects embedded in the wood, loose knots, or knots that may become loose during operation.
22. **WARNING!** DO NOT attempt to remove jams until power is disconnected and all moving parts have come to a complete stop.
23. MAKE SURE that there is adequate operating space on both the infeed and outfeed sides of the jointer before operating.
24. **WARNING!** DO NOT attempt to joint or plane wood that is less than 10" long, narrower than  $\frac{3}{4}$ ", or less than  $\frac{1}{2}$ " thick.

## GROUNDING INSTRUCTIONS

**WARNING!** This machine **MUST BE GROUNDED** while in use to protect the operator from electric shock. In the event of a malfunction or breakdown, **GROUNDING** provides the path of least resistance for electric current and reduces the risk of electric shock. The plug **MUST** be plugged into a matching electrical receptacle that is properly installed and grounded in accordance with **ALL** local codes and ordinances.

If a plug is provided with your machine **DO NOT** modify the plug. If it will not fit your electrical receptacle, have a qualified electrician install the proper connections to meet all electrical codes local and state. **ALL** connections must also adhere to **NEC** and **OSHA** mandates.

**WARNING!** **IMPROPER ELECTRICAL CONNECTION** of the equipment-grounding conductor can result in risk of electric shock. The conductor with the green insulation (with or without yellow stripes) is the equipment-grounding conductor. **DO NOT** connect the equipment-grounding conductor to a live terminal if repair or replacement of the electric cord or plug is necessary.

Check with a qualified electrician or service personnel if you do not completely understand the grounding instructions, or if you are not sure the tool is properly grounded.

**WARNING!** Electrocutation or fire could result if this machine is not grounded properly or if the electrical configuration does not comply with local and state electrical codes.

**MAKE CERTAIN** the machine is disconnected from power source before starting any electrical work.

**MAKE SURE** the circuit breaker does not exceed the rating of the plug and receptacle.

The motor supplied with your machine is a 115 volt, 60 hertz, single phase motor. Never connect the green or ground wire to a live terminal. A machine with a 115 volt plug should only be connected to an outlet having the same configuration as the plug.

**WARNING!** To reduce the risk of fire or electrical shock, use the proper gauge of extension cord. When using an extension cord, be sure to use one heavy enough to carry the current your machine will draw.

The smaller the gauge-number, the larger the diameter of the extension cord is. If in doubt of the proper size of an extension cord, use a shorter and thicker cord. An undersized cord will cause a drop in line voltage resulting in a loss of power and overheating.

**CAUTION!** **USE ONLY** a 3-wire extension cord that has a 3-prong grounding plug and a 3-pole receptacle that accepts the machine's plug. If you are using an extension cord outdoors, be sure it is marked with the suffix "W-A" ("W" in Canada) to indicate that it is acceptable for outdoor use.

## GROUNDING INSTRUCTIONS (cont.)

Make certain the extension cord is properly sized, and in good electrical condition. Always replace a worn or damaged extension cord immediately or have it repaired by a qualified person before using it.

Protect your extension cords from sharp objects, excessive heat, and damp or wet areas.

MINIMUM RECOMMENDED GAUGE FOR EXTENSION CORDS (AWG)				
115 VOLT OPERATION ONLY				
	25' LONG	50' LONG	100' LONG	150' LONG
0 to 6 Amps	18 AWG	16 AWG	16 AWG	14 AWG
6 to 10 Amps	18 AWG	18 AWG	14 AWG	12 AWG
10 to 12 Amps	16 AWG	16 AWG	14 AWG	12 AWG

## UNPACKING & INVENTORY

Check shipping carton for damage before unpacking. Carefully remove packaging materials, parts and machine from shipping carton. Always check for and remove protective shipping materials around motors and moving parts. Foam weather stripping under the tables near the cutterhead should remain in place. Lay out all parts on a clean work surface.

**Be EXTREMELY CAREFUL working around the cutter tips as they are VERY SHARP!!!**

Remove any protective materials and coatings from all of the parts and the jointer **except** for the cutterhead. Specific cutterhead cleaning instructions follow. The protective coatings can be removed by spraying WD-40 on a soft cloth and wiping the surfaces.

**After cleaning, apply a good quality paste wax to the table surfaces being careful of the cutterhead. Make sure to buff out the wax before assembly. This will keep your stock sliding smoothly and keep rust from forming on the tables.**

**NOTE: Some parts pictured may already be installed on your machine at the factory.**

Go through the entire manual before contacting WAHUDA.

Compare the items to inventory figures and verify that all items are accounted for. If any parts are missing, do not attempt to power on the machine. For missing parts, or shipping damage, contact WAHUDA at [techservices@wahudatools.com](mailto:techservices@wahudatools.com) or call **877-568-8879**.

# IN THE BOX

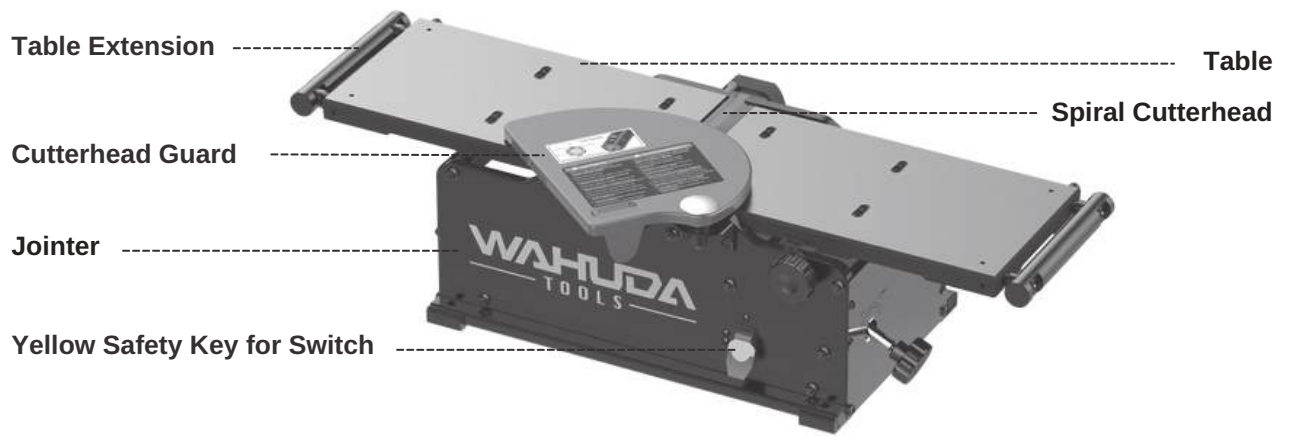

**Fence Sliding Bracket**



**Fence Bracket**



**Fence**



**Dust Port**



**Dust Port Adaptor**

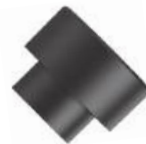

**2ea Push Blocks**



**Sliding Bracket Lever**



**Sliding Bracket Washer**



**Sliding Bracket Nut**



**2ea Fence Square Nuts & Screws**



**T Torx Handle**



**4 mm Allen Key  
2.5 mm Allen Key**



## IN THE BOX

Stabilizer x 2



Cushion x 2



Locking Knob x 2



## FENCE STABILIZER SYSTEM FOR JOINTERS

Introducing the new Wahuda Fence Stabilizing System . Help in preventing movement of the fence during operation and can be installed on Wahuda Machines and most competitive models at very affordable prices.

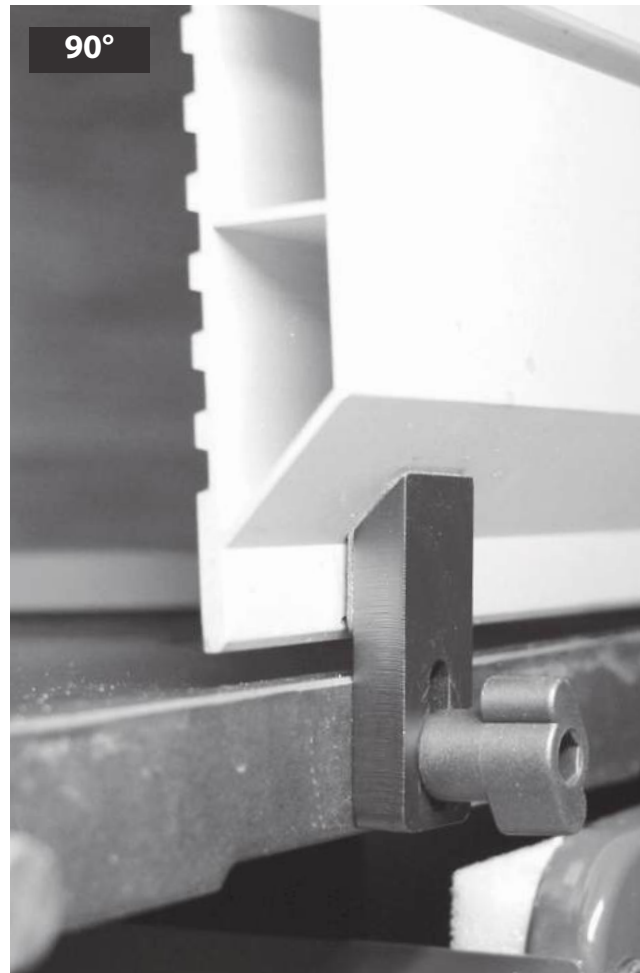
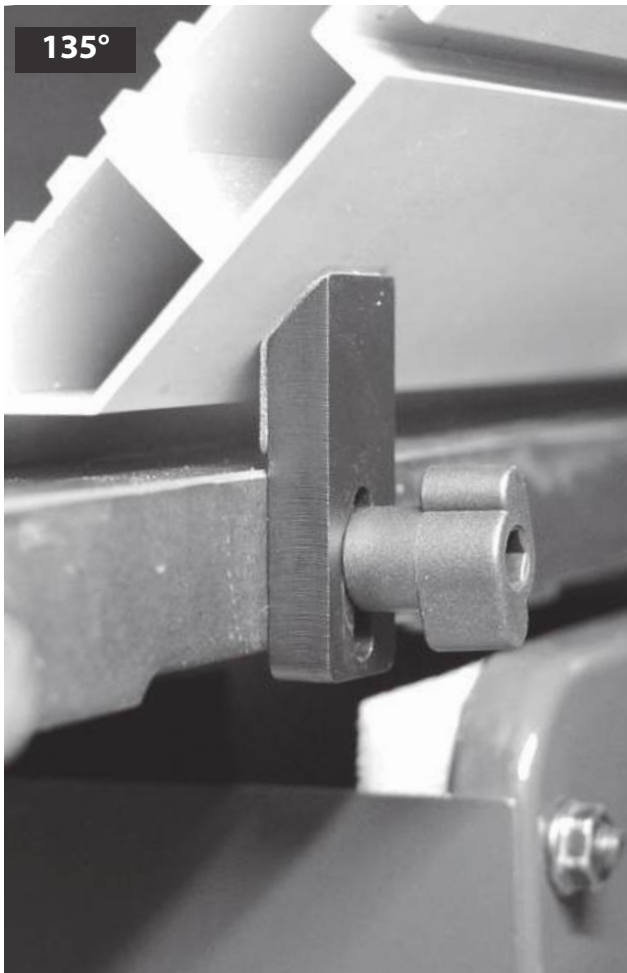

## ASSEMBLY & ADJUSTMENTS

**WARNING!** MAKE CERTAIN THAT THE MACHINE IS DISCONNECTED FROM THE POWER SOURCE BEFORE ASSEMBLY AND ADJUSTMENTS

### FENCE ASSEMBLY PROCEDURE

1. Face the rear of the jointer and remove the 4 screws (A) using the provided 4mm Hex Wrench. See FIG 1

**FIG 1**

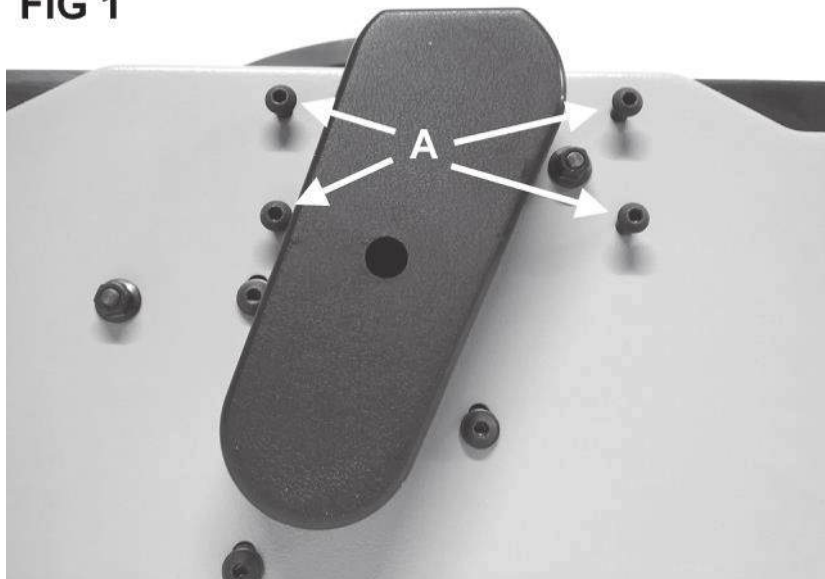

2. Using the provided 4mm Hex Wrench, install Fence Bracket (See inventory page 13) using the 4 screws removed in the previous step. Tighten screws securely. See FIG 2

**FIG 2**

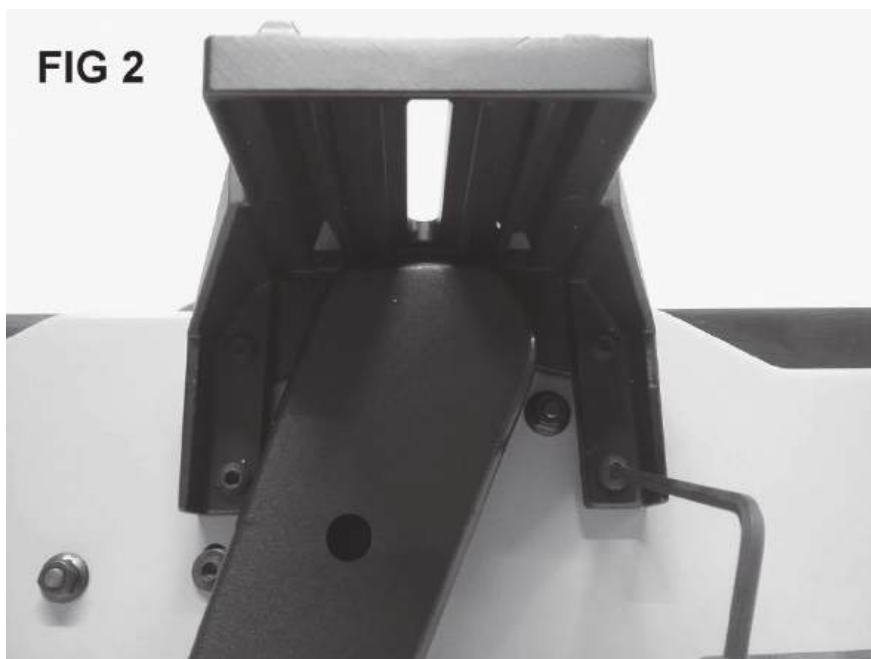

## ASSEMBLY & ADJUSTMENTS (cont.)

3. Locate the Fence Sliding Bracket (See page 13) and the 2 screws and 2 square nuts (See page 13). Insert screws through the Fence Sliding Bracket upper holes "A" in FIG 3, and thread the square nuts on by hand about 3 complete turns. See FIG 4. Do not tighten at this time.

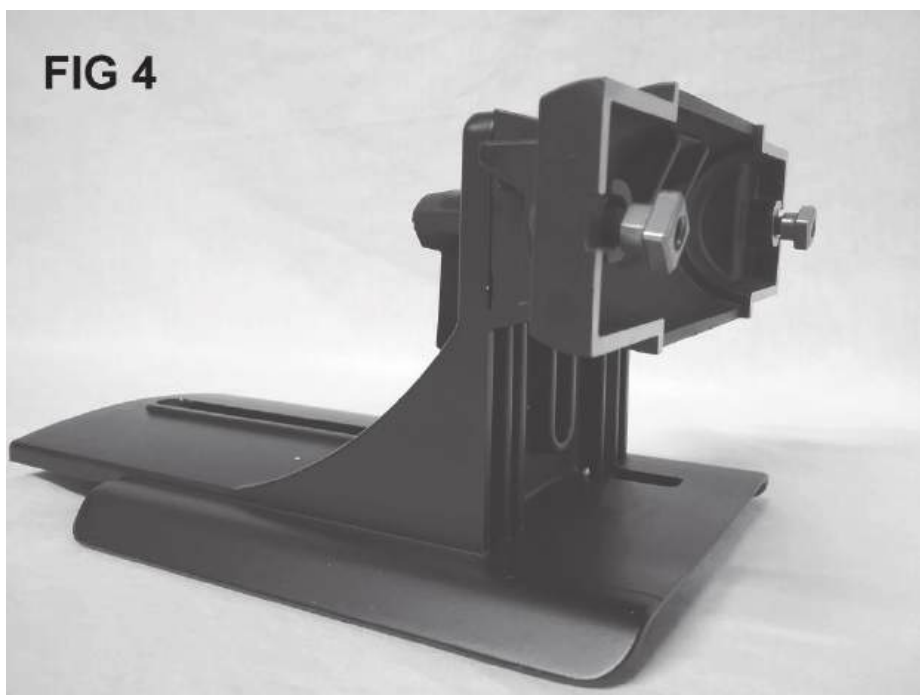
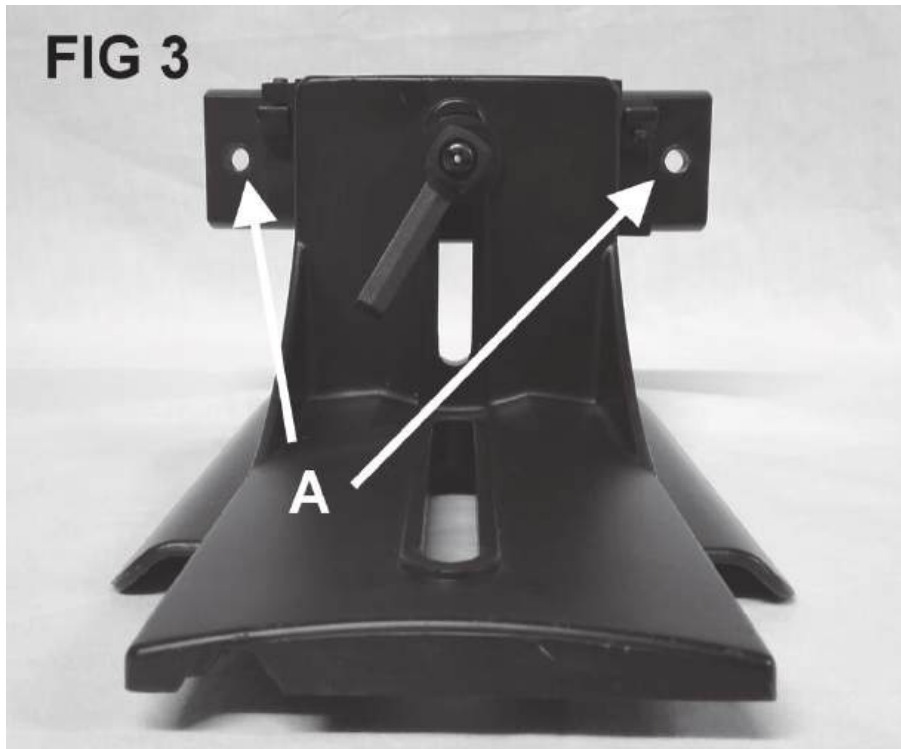



## ASSEMBLY & ADJUSTMENTS (cont.)

4. Locate fence (See page 13) and slide from end, with the back of fence facing bracket, over the square nuts as shown in FIG 5. Note that the bottom of the fence is beveled and the square nuts have flats on them so you may have to rotate them slightly to slide the fence on.

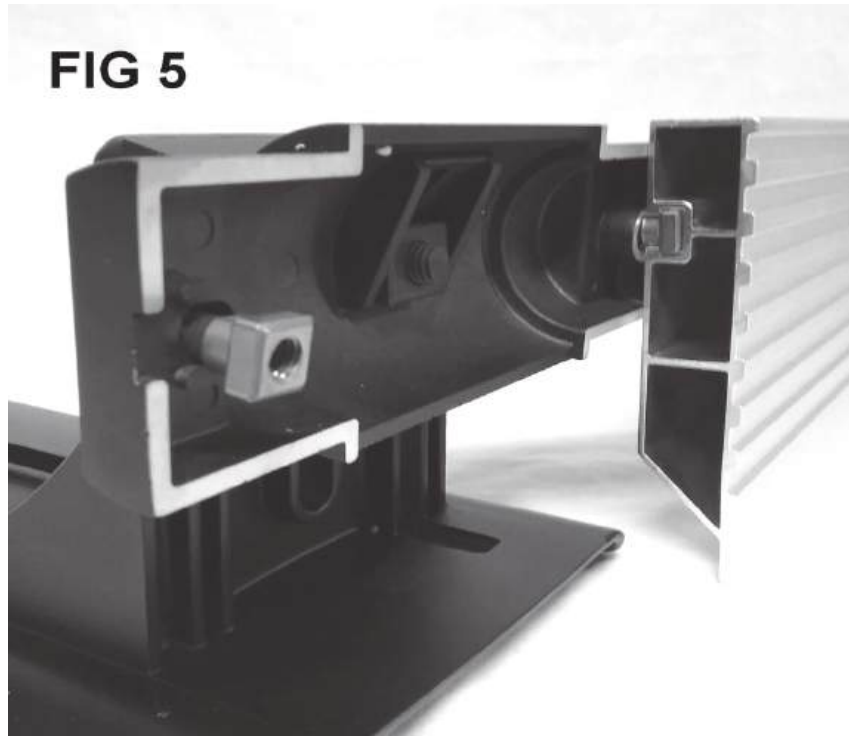

5. Slide the fence until centered on the bracket and then tighten the 2 screws used in step 3 using the 4mm Hex Wrench. The arc shaped cut out on the bottom edge of the fence should be centered over the cutterhead. See FIG 6

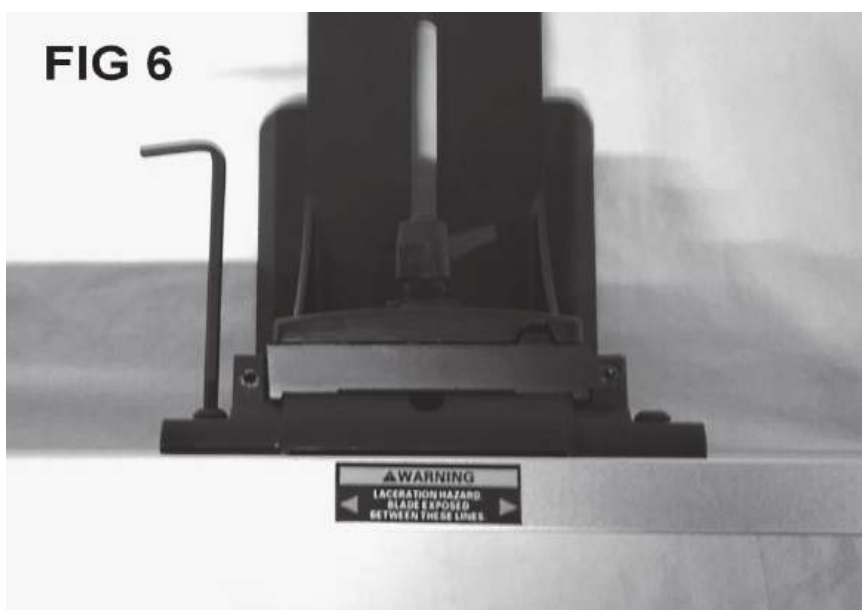

## ASSEMBLY & ADJUSTMENTS (cont.)

6. Facing the rear of the jointer, place the Sliding Bracket Fence Assembly onto the Fence Bracket and slide forward (towards front of the jointer) until the table holes are half exposed as shown in FIG 7.



7. Locate Sliding Bracket Lever, Washer & Nut (See page 13). Place the nut under the Bracket with the convex surface facing downward. Then place the washer on top of the Sliding Bracket and place the Lever through the washer and thread into the convex nut just enough until fence still slides freely. See FIG 8 and FIG 9. Then slide the fence assembly completely back.

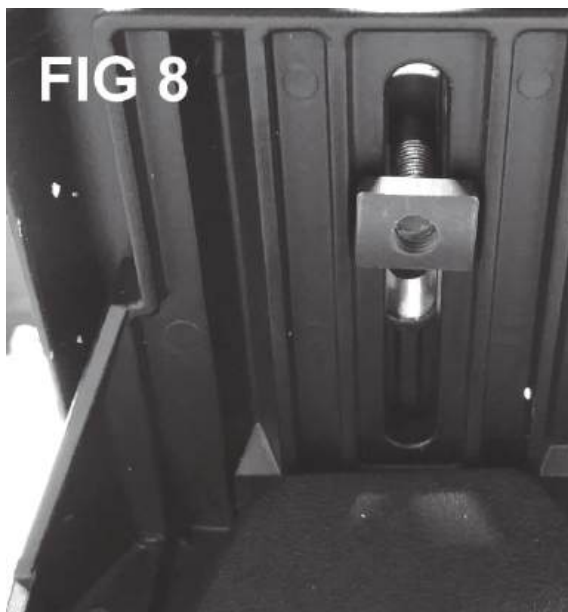

## ASSEMBLY & ADJUSTMENTS (cont.)

### CUTTERHEAD GUARD

The cutterhead guard has a tension return spring. The tension on this spring is set at the factory. When the guard is installed properly it should return to the fence automatically after the work piece has passed over the cutterhead. Be sure the guard is functioning properly every time before using the jointer.



### DUST PORT & ADAPTER

A dust port (A) is supplied with the jointer to help connect it to a standard 4 inch vacuum hose. If needed for 2-1/2" vacuum hose, you can convert it by the supplied adapter (B). Use 2 machine screws to attach the top of the dust port and 2 tap screws into the rubber feet to attach the dust port.



## ASSEMBLY & ADJUSTMENTS (cont.)

### FENCE ADJUSTMENTS

The fence can be tilted from 90 to 135 degrees. There are 2 adjustable stop set screws for these limits. See FIG 17 for the location of these set screws.

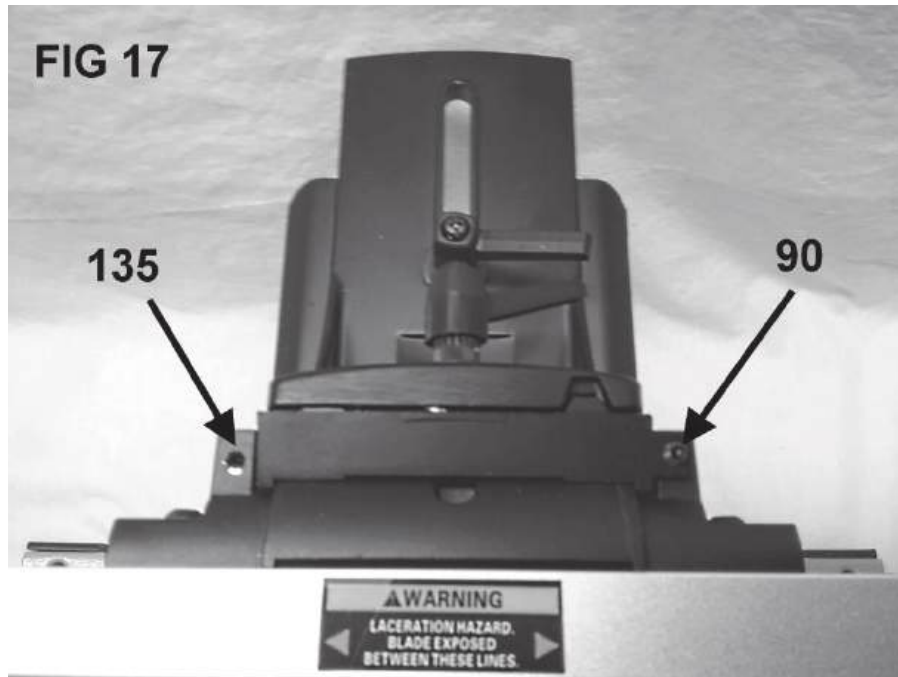

1. To set the 90 degree stop, slightly loosen fence lever "B", which locks the fence in place, and lift fence slightly clearing tables and slide fence forward approximately 1 inch. Leave fence lever "B" slightly loose. Tighten Fence Sliding Bracket Lever "A". Lift fence about 1/16" above the table. You can use shims, such as playing cards, to help keep the fence raised off of the tables. Do not let fence rest on table when making these adjustments as it will move when tightening lever "B". Place a square against the fence and use the provided 2.5mm Hex Wrench "C" to adjust the 90 degree set screw against the stop. See FIG 18 and FIG 19. The set screw should just come in contact with the stop when adjusted for 90 degrees. Tighten lever "B" and remove shims to check again with square to see if fence stays at 90 degrees. If not, repeat above procedure.

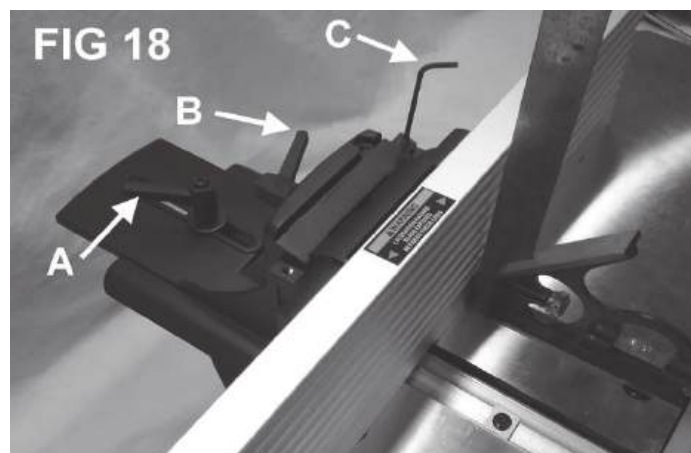

## ASSEMBLY & ADJUSTMENTS (cont.)

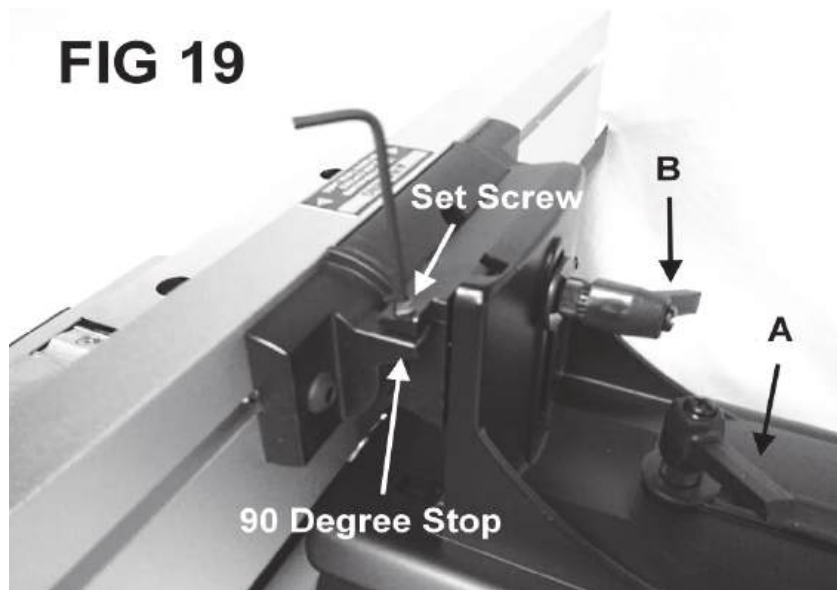

2. To set the 135 degree stop, slightly loosen lever “B” and loosen fence lever “A”. Slide the fence back completely and re-tighten lever “A”. Place a 45 degree angle against the fence, insert shims under fence, and use the provided 2.5mm Hex Wrench to adjust the 135 degree set screw against the stop. **NOTE:** The set screw is set deep into the angled hole at the factory. If necessary, use a flashlight to locate it. See FIG 20 and FIG 21. Once adjusted, tighten lever “B”, remove the shims, and check for 45 degrees. If not at 45, repeat above procedure. You can now use fence lever “B” to lock the fence at the angle you choose.

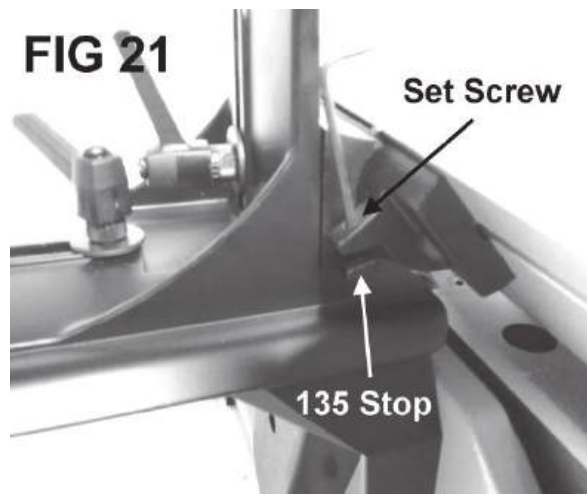

**NOTE:** These positive stops enable you to quickly position the table to the 90 and 135 degree settings.

## (Optional) CLEANING SPIRAL CUTTERHEAD & TIPS

**WARNING!** MAKE CERTAIN THAT THE MACHINE IS DISCONNECTED FROM THE POWER SOURCE BEFORE PERFORMING ANY MAINTENANCE PROCEDURES

**NOTE:** *WAHUDA* spiral cutterheads are machined with a film of oil that may be left over from the process. Run pieces of scrap to remove the residue if apparent. If residue is still present after machining scrap, only then perform the following procedures.

**WARNING!** To prevent serious personal injury NEVER rotate the cutterhead by hand. Cutter tips are razor sharp! Always wear heavy leather gloves when handling the cutterhead. Avoid touching the cutter insert by hand without protection.

Step 1 - Place the machine at a comfortable working height and supply ample lighting. The cutterhead guard should still be removed from previous instructions.

Step 2 - NOTE: Do not get solvent on any painted portion of the machine.

Use the supplied 4mm Hex Wrench inserted into the end of the cutterhead at front of jointer to rotate and hold cutterhead into position. Then, using the supplied T-25 T-Torx Wrench (See page 13), carefully remove the cutter tips. Continue rotating the cutterhead with the Hex Wrench and remove the remaining tips. See FIG A



## CLEANING SPIRAL CUTTERHEAD & TIPS (cont.)

Step 3 - Separate the tips from the screws and place in separate containers with a bit of mineral spirits or non-chlorinated brake cleaner. Once all are removed, wipe down the bare cutterhead using rags with whichever solvent you chose. Once the oil is wiped off, use an air compressor or a can of pressurized air to clear each seat and screw hole on the cutter head. This will aid in knife and cutter tips reinstallation.

Step 4 - Lubricate the Torx screw threads with light machine oil, wipe the excess oil off the threads, Place each knife in the seat and slightly snug each screw using the Hex Wrench to hold the cutterhead in position. Once you get a row of tips seated and slightly tightened down, repeat by going back over each cutter tip and tighten down the screws securely to **48 to 50 inch / lbs.**

**NOTE: NOT FT/LBS !**

After all assembly and adjustment instructions are completed, use a sacrificial board after cleaning to test for remaining oil. If oil is still apparent, repeat the cleaning method you used above.



## OPERATIONS

**NOTE: USE SCRAP STOCK TO FIRST TO CHECK JOINTER SET UP AND OPERATIONS. ONCE YOU HAVE DESIRED RESULTS, ONLY THEN USE YOUR PROJECT STOCK**

NOTE: This operations section was designed to give instructions on the basic operations of this jointer. However, it is in no way comprehensive of every jointer operation. It is strongly recommended that you read books, trade magazines, or get formal training to maximize the potential of your jointer, and learn hand placement while minimizing the risks.

**WARNING!** NEVER PRESS DOWNWARD DIRECTLY OVER THE CUTTERHEAD.

**WARNING!** ALWAYS USE CUTTERHEAD GUARD, PUSH BLOCKS, AND KEEP HANDS AWAY FROM CUTTERHEAD.

NOTE: THE TIPS ON THE JOINTER WILL NOT WEAR EVENLY BY FEEDING THE WOOD THROUGH THE SAME SPOT ON THE TABLE EVERY TIME. FEED THE WOOD THROUGH THE JOINTER AT DIFFERENT SPOTS ON THE TABLE BY REPOSITIONING THE FENCE, WHEN POSSIBLE, TO HELP ELIMINATE UNEVEN WEAR OF THE TIPS.

### STARTING AND STOPPING JOINTER

1. The on/off switch (A) is located on the front of the jointer. To turn the jointer "ON", fully insert yellow safety key and move switch (A) upwards.
2. To turn the jointer "OFF", move the switch downwards and remove safety key. See below

**WARNING!** Remove yellow safety key when unit is not in use to prevent unauthorized operation

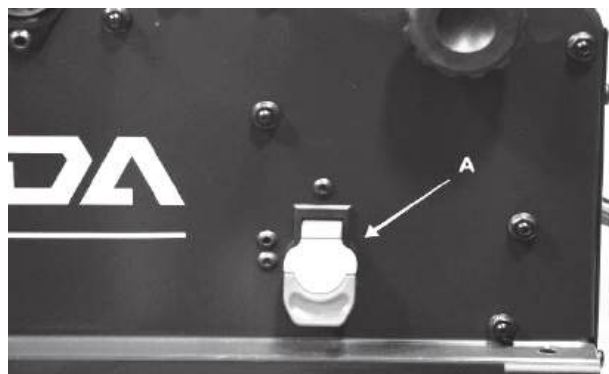



## OPERATIONS (cont.)

### DIRECTION OF GRAIN

Avoid feeding work into the jointer against the grain. The result will be chipped and splintered edges or tear out. Feed with the grain to obtain a smooth surface. See FIG 25

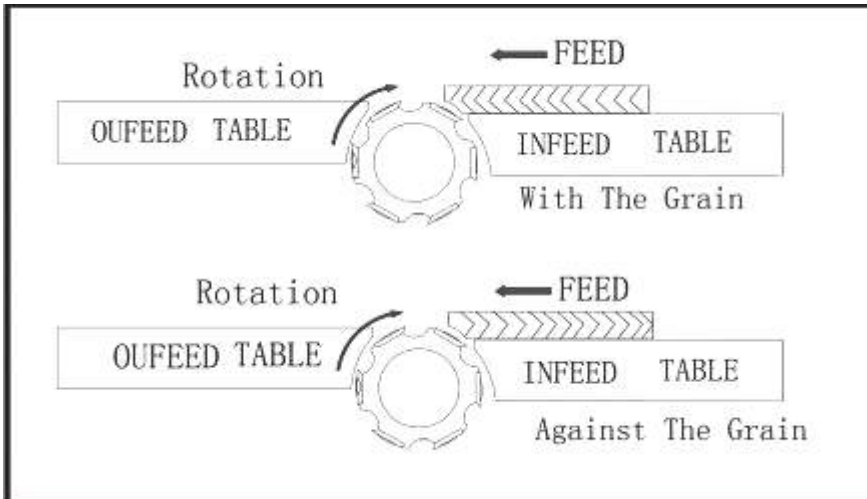
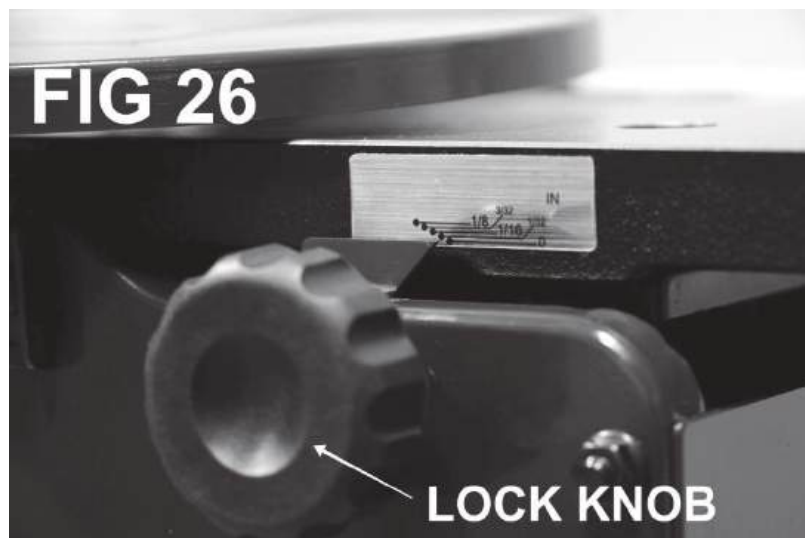

FIG 25

The jointer can be set to cut any depth from a very thin shaving to 1/8" deep. The pointer on the scale is to indicate the depth of cut. To adjust the depth of cut, loosen front lock knob and turn infeed table raise / lower knob clockwise to lower and counterclockwise to raise the infeed table until the infeed table is at the desired position. Retighten lock knob. See FIG 26



## OPERATIONS (cont.)

### PLACEMENT OF HANDS DURING FEEDING

At the start of the cut, the left hand holds the work against the infeed table and fence, while the right hand pushes the work down and toward the knives. After the cut is underway, the new surface rests on the outfeed table. The left hand should then be moved to the work on the outfeed table, at the same time maintaining flat contact with the fence. The right hand presses the work forward, and before the right hand reaches the cutterhead, it should be moved to the work on the outfeed table to pull the rest of the board through.

### SURFACING / PLANING

Surfacing is similar to the edge jointing operation except for the position of the work piece. For surfacing, the major flat surface of the work piece is placed on the infeed table of the jointer with the narrow edge of the work piece against the fence. The work piece is moved from the infeed table, across the cutterhead to the outfeed table, establishing a flat surface on the work piece.

**WARNING!** ALWAYS USE PUSH BLOCKS WHEN PERFORMING SURFACING OPERATIONS AND NEVER PASS YOUR HANDS DIRECTLY OVER THE CUTTERHEAD.  
See FIG 27



## OPERATIONS (cont.)

### JOINTING AN EDGE

This is the most common operation for the jointer. These cuts are made to square an edge of a work piece that already has one flat face to rest against the fence. Set the fence square with the table. Depth of cut should be the minimum required to obtain a straight edge. Hold the flat face your previously machined against the fence and downward with a push block throughout the feed. See FIG 28

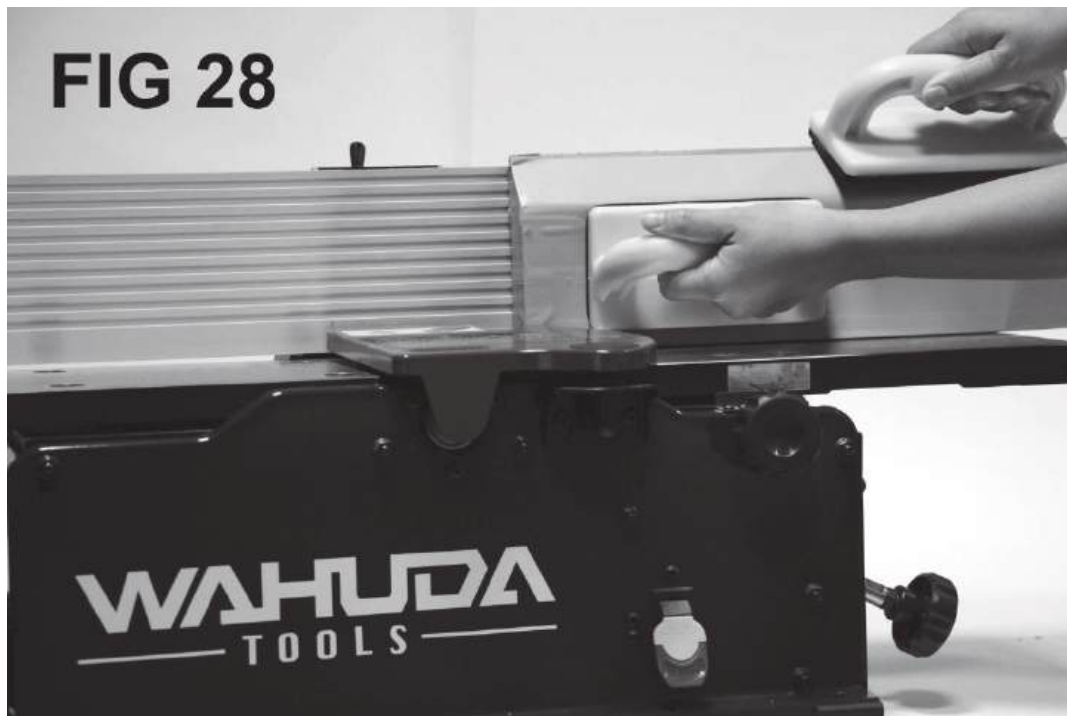

### OTHER OPERATION INSTRUCTIONS

- Do not perform jointing operations on material shorter than (a dimension equal to the cutter head length plus 2 in), narrower than  $\frac{3}{4}$  in, or less than  $\frac{1}{4}$  in thick.
- Do not perform planing operations on material shorter than (a dimension equal to the cutter head length plus 2 in), narrower than  $\frac{3}{4}$  in, or wider than (the cutter capacity in inches) or thinner than  $\frac{1}{2}$  in.
- Maintain the proper relationships of infeed and outfeed table surfaces and cutter head knife path.
- Support the work piece adequately at all times during operation; maintain control of the work at all times.
- Do not back the work toward the infeed table.
- Do not attempt to perform an abnormal or little-used operation without study and the use of adequate hold-down/push blocks, jigs, fixtures, stops, and the like

## OPERATIONS (cont.)

### UNDESIREBALE RESULTS

**NOTE: Rough sawn , bowed, cupped, or twisted stock will take several passes before a smooth finish is achieved. Apply light downward pressure to this type of stock and take very shallow depth of cut passes to eliminate stock waste and bowed surfaces. Research proper jointing methods for imperfect lumber.**

If you are getting scalloping (aka chatter marks) on the surface of your stock, this is due to error of the operator feeding too fast. Slow down your feed speed.

After machining the face of a piece of lumber and you find the stock is thinner on one long edge than the other, the most likely cause is the infeed table not being parallel with the cutterhead. See the table adjustment procedures in the Troubleshooting section beginning on page 33 of this manual.

If you find that you are not getting a square edge to an already flat face surface, and the fence is not square to both tables when checked separately, the tables need to be adjusted to coplanar. See the table adjustment procedures in the Troubleshooting section beginning on page 33 of this manual.

If both tables are coplanar to each other and parallel with the cutting edges of the inserts on the cutterhead, and you are not getting a square edge to a flat face surface, go through the fence adjustment procedures beginning on page 19 of this manual.

After making a few passes on either a single face, or single edge, are you beginning to see a taper on your piece of stock? That's normal. The more you continue to run the same face or edge, the worse the taper will be. A jointer can only square up one face and one edge. It does not have any type of opposite side reference to machine 2 parallel surfaces. There are videos and write ups on the internet explaining why this happens. You need a planer to create a parallel face surface to the flat jointed face of your stock and a table saw to rip cut a parallel edge to the jointed edge. This will give you a board with 4 surfaces that are square to each other and opposite faces that are parallel with each other....aka S4S lumber.

If you are getting either a concave or convex face or edge, this most likely means your tables are not coplanar and need to be adjusted, or you are applying too much downward pressure on a bowed or cupped board causing the issue. For table adjustments, see the table adjustment procedures in the Troubleshooting section beginning on page 33 of this manual.

NOTE: We highly recommend reading articles and watching videos on how to properly machine stock that is warped, bowed, twisted or cupped, before making table adjustments as undesirable results could just be operator error.

## MAINTENANCE

**WARNING!** MAKE CERTAIN THAT THE MACHINE IS DISCONNECTED FROM THE POWER SOURCE BEFORE PERFORMING ANY MAINTENANCE PROCEDURES

Your jointer should provide you with a long time of service provided you take the time to perform the following maintenance operations.

### **CLEANING**

Sawdust buildup and other debris can cause the tool to joint and plane incorrectly. Periodic cleaning and waxing is needed for accurate precision planing and jointing. Any moving parts should be cleaned regularly and lubricated with a light coating of medium weight machine oil.

**CAUTION!** With the machine unplugged, blow off motor with low pressure air to remove dust or dirt. Air pressure above 50 P.S.I. should not be used as high-pressured air may damage insulation. The operator should always wear a respirator and eye protection when using compressed air. Do not allow chips and dust to accumulate under the machine. Keep area clean and in safe order.

### **HARDWARE TIGHTNESS**

Periodically check all clamps, nuts, bolts, and screws, for tightness and condition. Stop the machine, and with the machine unplugged, recheck the cutterhead screws and tips, for tightness after about 50 hours of operation. Recheck periodically.

**NOTE:** Remember to do the regular maintenance described in your manual. To feed properly, the jointer and tables need periodic cleaning, waxing and buffing.

## MAINTENANCE (cont.)

**WARNING!** MAKE CERTAIN THAT THE MACHINE IS DISCONNECTED FROM THE POWER SOURCE BEFORE PERFORMING ANY MAINTENANCE PROCEDURES

CUTTER TIP REPLACEMENT – USE PAGES 21 - 22 FOR REFERENCE IF NECESSARY

**WARNING:** To prevent serious personal injury NEVER rotate the cutterhead by hand. Cutter tips are razor sharp! Always wear heavy leather gloves when handling the cutterhead. Avoid touching the cutter insert by hand without protection.

The 10" cutterhead is equipped with 20 indexable 4-sided carbide cutter inserts. Each cutter insert can be rotated to reveal any one of its four cutting edges. Therefore, if one cutting edge becomes dull or damaged, simply rotate it 90° to reveal a fresh cutting edge.

In addition, each cutter insert has a reference mark on one corner. As the cutter insert is rotated, the reference mark location can be used as an indicator of which edges are used and which are new. See FIG B & C

### FIG B

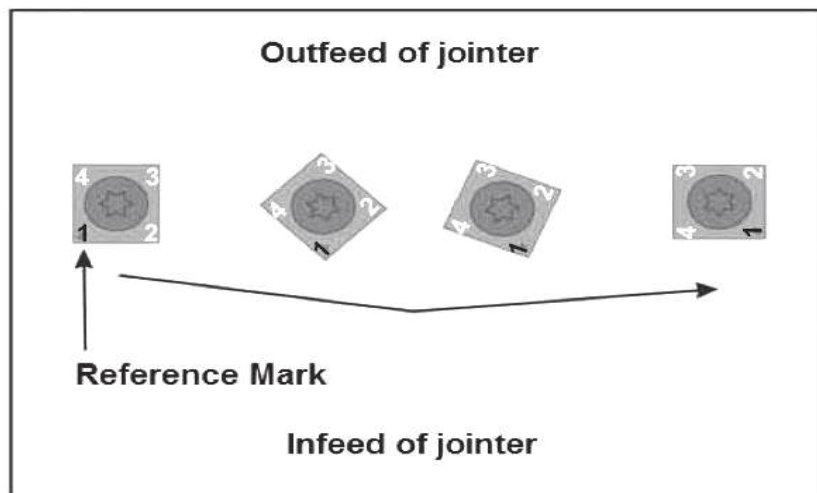

### FIG C

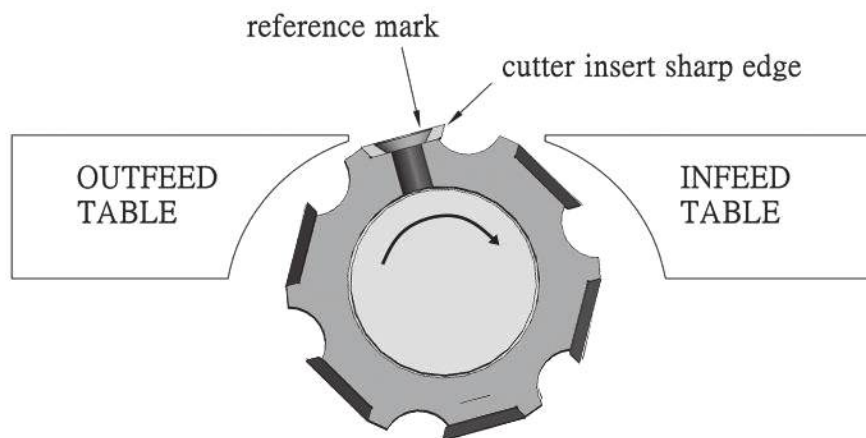

## MAINTENANCE (cont.)

### DISCONNECT THE JOINTER FROM THE POWER SOURCE!

- Remove any sawdust from the head of the Torx screw.
- Remove the Torx screw and Cutter insert.
- Clean all dust and dirt off the cutter insert and the cutterhead pocket from which the cutter insert was removed, and replace the cutter insert so a fresh, sharp edge is facing outward. Use mineral spirits or non-chlorinated brake cleaner to remove the wood residue off the cutterhead and cutter insert before attempting to rotate them. Using a shot of compressed air is also helpful, be sure to wear safety glasses.

Lubricate the Torx screw threads with light machine oil, wipe the excess oil off the threads, and torque the Torx screw to **48-50 inch/ pounds NOT FT/LBS!** . When rotating a cutter insert, the cutter insert will seat itself before tightening.

### REPLACING THE BELT

#### **WARNING! MAKE CERTAIN THAT THE MACHINE IS DISCONNECTED FROM THE POWER SOURCE BEFORE REPLACING BELT**

1. Place protective material on work surface and lay jointer on its front with rear belt cover facing up and the open bottom facing you. Use scrap pieces to balance the jointer.
2. Use the 4mm Hex Wrench to remove the belt guard. See FIG 29



## MAINTENANCE (cont.)

3. Loosen the 3 motor mounting screws "A", "B" and "C", about 1 full turn. See FIG 30

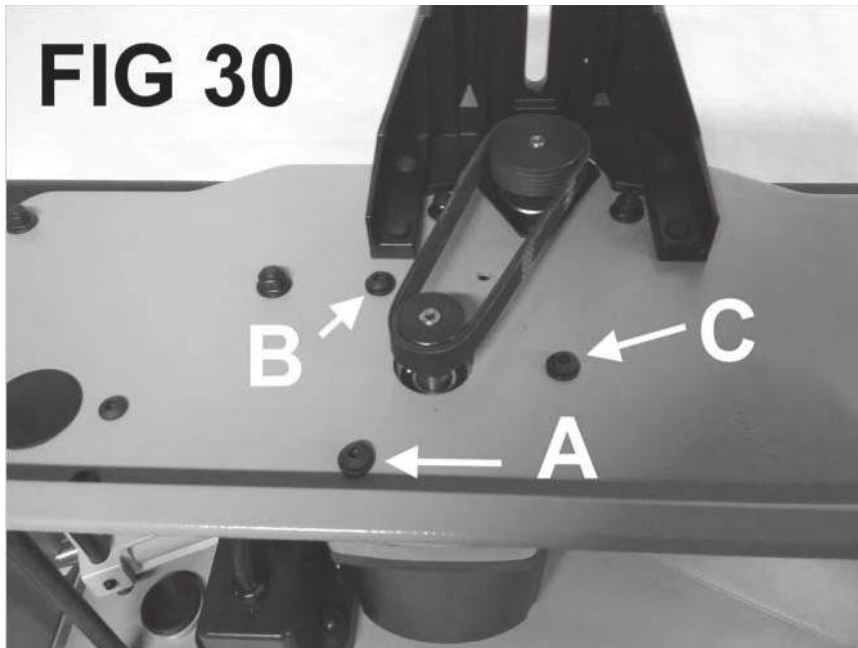

4. From the exposed open base, gently push motor away from you with left hand to release belt tension and rotate the belt to walk the belt off the motor pulley with your right hand. See FIG 31





## MAINTENANCE (cont.)

5. Place new belt over cutterhead pulley and walk belt onto the motor pulley. Make sure that the belt is seated in all cutterhead and motor pulley grooves. Pull right side of motor, to begin tensioning belt, and snug up screw "C". Do not securely tighten "C" at this time. See FIG 32

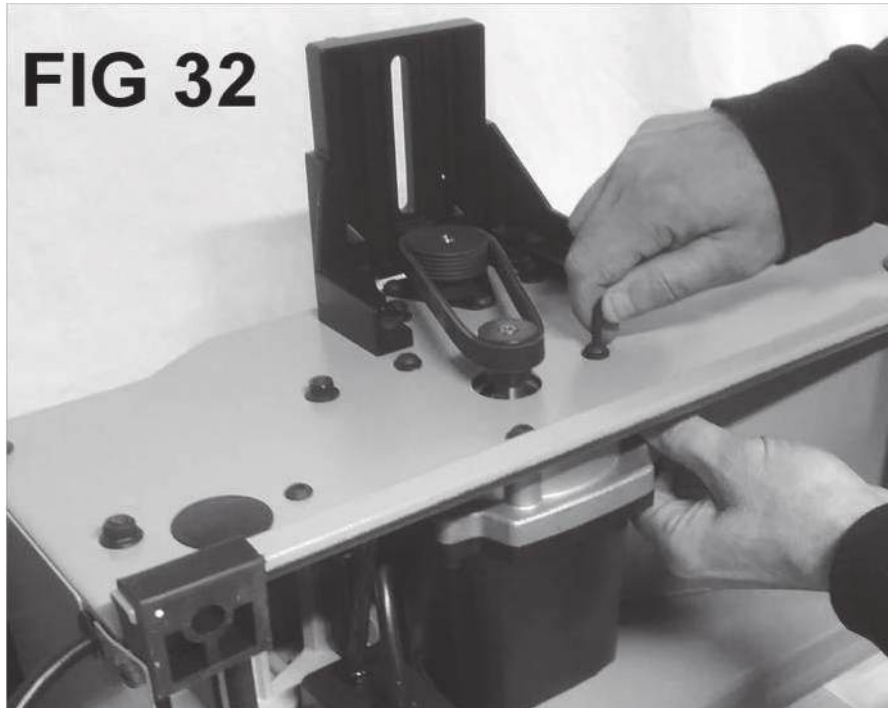

6. Pull left side of motor, further tensioning belt, and snug up screw "B". See FIG 33. Repeat steps 5 and 6 if belt is not tensioned properly. Once proper belt tension has been achieved, securely tighten screws "A", "B" and "C" and replace belt cover.



# TROUBLESHOOTING GUIDE

## INFEEED / OUTFEED TABLE COPLANAR AND CUTTERHEAD PARALLELISM CHECK

**NOTE:** Do not attempt these adjustments before running pieces of scrap test stock to make sure there is an issue with the jointer and not an operator or a previous set up error.

The following diagrams show several incorrectly adjusted tables, and lastly, correctly adjusted tables. Please view and understand all before proceeding to the adjustment instructions. **NOTE: You will need to go back and check the fence stops if table adjustments are necessary beginning on page 19.**

**Note: The following 3 diagrams show incorrectly adjusted tables that can cause concave surfaces**

Incorrect Adjustment

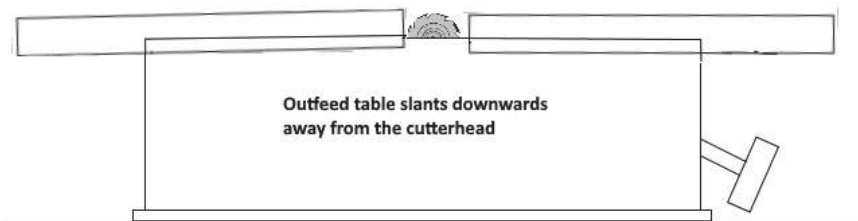

Incorrect Adjustment

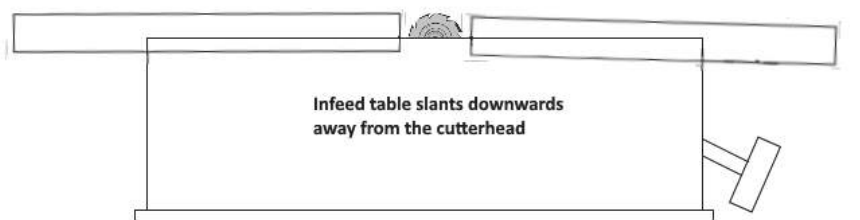

Incorrect Adjustment

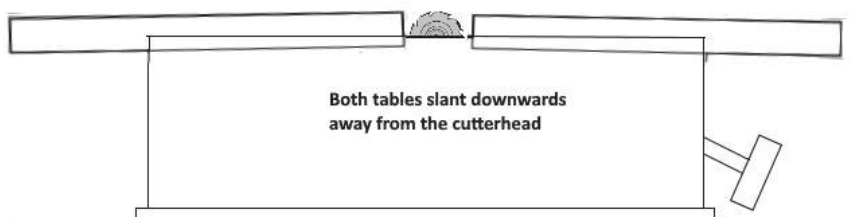

## TROUBLESHOOTING GUIDE (cont)

**NOTE: The following 3 diagrams show incorrectly adjusted tables that can cause convex surfaces**

Incorrect Adjustment

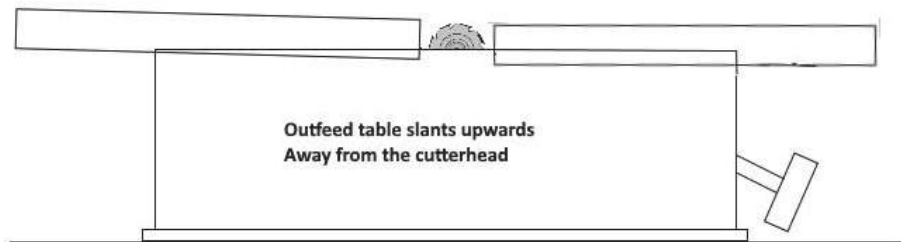

Incorrect Adjustment

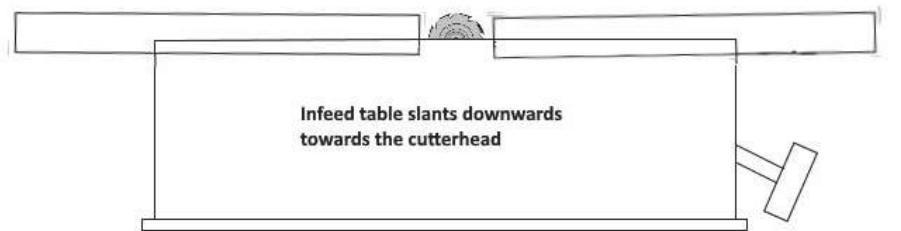

Incorrect Adjustment

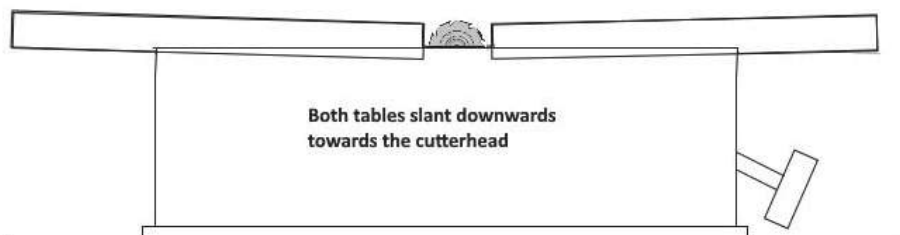

# TROUBLESHOOTING GUIDE (cont)

## Incorrect Adjustment

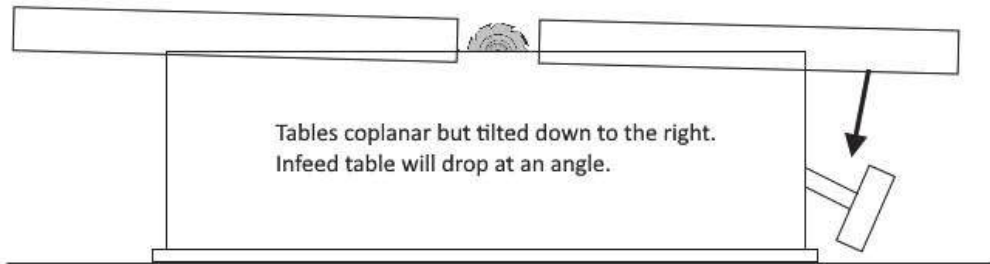

## Incorrect Adjustment

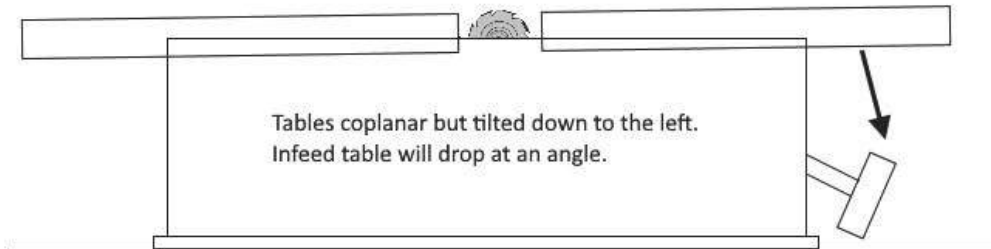

## CORRECT ADJUSTMENT

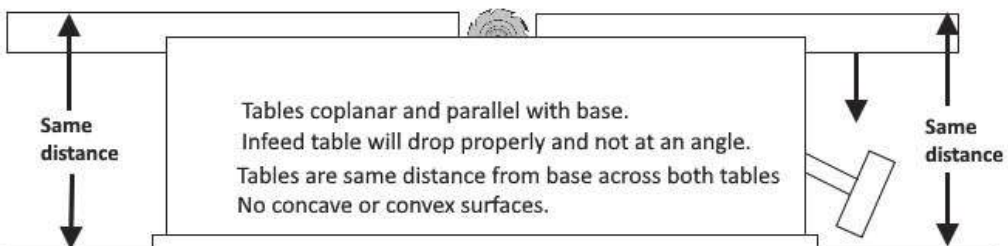

## TROUBLESHOOTING GUIDE (cont)

The infeed and outfeed tables have been adjusted at the factory before shipment. There is a possibility that they may have shifted due to it being dropped, rolled, or impacted during shipment, and are no longer coplanar or parallel to the cutterhead. If you are getting undesirable results, a check should be performed using a metal straight edge of at least 24" in length.

### **REMINDER: BE EXTREMELY CAREFUL when working around the cutterhead!!!**

1. Locate the 2 screws holding the cutterhead guard bracket and loosen the screws "A" in FIG 10. Grasp the guard and guard bracket as shown and slide up and pull out to remove. See FIG 11  
**NOTE:** The cutterhead guard has a tension return spring. The tension on this spring is set at the factory. When the guard is installed properly it should return to the fence automatically after the work piece has passed over the cutterhead. Be sure the guard is functioning properly every time before using the jointer.

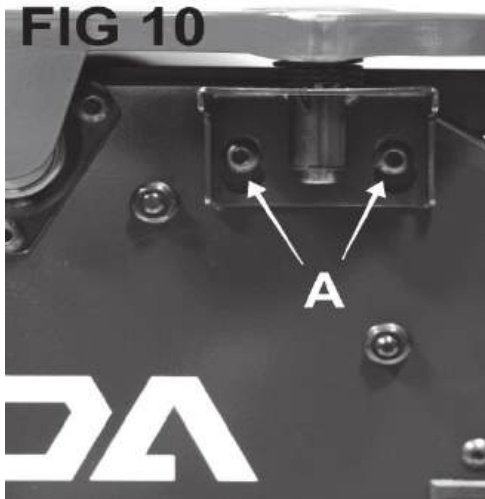

## TROUBLESHOOTING GUIDE (cont)

2. Lower the infeed table to its lowest setting by rotating Infeed Table Lock Knob “A” counterclockwise to loosen and rotate the Infeed Table Lower/Raise Knob “B” clockwise to lower the table. See FIG 12



3. Place a metal straight edge at least 24” in length on the outfeed table across the cutterhead near the fence and over the cutterhead tip nearest the fence to check for parallelism. Insert the small hex wrench into the crossed-drilled hole at end of the cutterhead and rotate the cutterhead counter-clockwise until the tip nearest the fence is at its apex. The straight edge should lie flat on the outfeed table and the cutter tip should just touch the straight edge without lifting it or be slightly lower than the straight edge. Slight movement of the straight edge is OK. Move the straight edge towards the front of the machine and repeat above step for front edge of table and cutterhead tip nearest front of machine. If outfeed table is parallel to the cutterhead, jump to page 39. If the straight edge is lifted when rotating the cutterhead, the outfeed table is too high and needs to be adjusted lower.

See FIG 13 and FIG 14



## TROUBLESHOOTING GUIDE (cont)

If the outfeed table is not parallel with the cutterhead tips, remove the table hole plugs to expose the table hold down and adjustment screw holes using your finger or appropriate tool of your choice. See below.

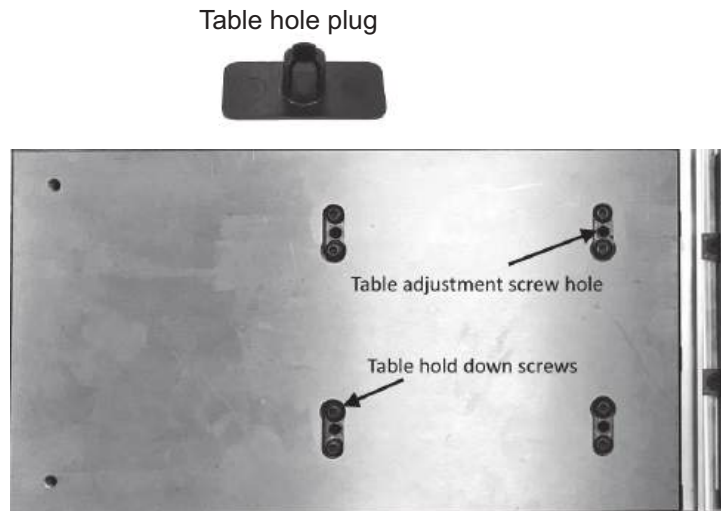

NOTE: Please keep in mind the previous diagrams on pages 33 through 35 when making adjustments to avoid issues.

NOTE: One full turn on either the table hold down screws, or leveling screws, equals 1 mm which is .040 thousands or 3/64". Thus, only make slight adjustments to the leveling screws until proper height is achieved.

4. If an adjustment needs to be made, loosen the 2 table mounting screws in the table with the T25 T-Torx wrench where the adjustment needs to be made. In between the hold down screws is a hole in which the Torx wrench can be inserted to adjust the leveling screw (pictured below) under the table to raise or lower it. Turn counter clockwise to raise the table and clockwise to lower it. Once the table is adjusted properly, retighten the hold down screws and recheck the table front and back with your straight edge. Repeat this procedure if any further adjustments are necessary keeping in mind the previous diagrams on pages 33 through 35.



## TROUBLESHOOTING GUIDE (cont)

Once the outfeed table is properly adjusted, you can reinsert the table plugs and then move onto the infeed table to check if adjustments are necessary. Do not go back and readjust the outfeed table once you have started the infeed table adjustments as this will force you to start over.

5. Loosen the front lock for the infeed table enough to expose the threads behind it. See picture below.



6. Raise the infeed table, using the crank knob underneath it, until the threaded portion of the lock knob just begins to touch the top of the slotted hole (see above) This would place the infeed table at zero depth of cut relative to the outfeed table. If the depth of cut label is not at zero, you can reposition it later after adjustments are made, or we can send you a replacement label after adjustments have been made.

7. With the straight edge across both tables, check to see if the infeed table is coplanar to the outfeed table at the front and back of the machine See FIG A and B below.

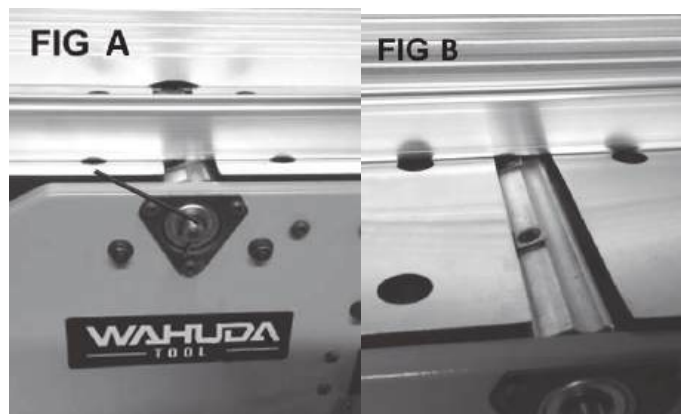

The infeed table should be coplanar across its length with the outfeed table both at the front and rear of the machine. If the infeed table is not coplanar to the outfeed table, remove the hole plugs in it, and perform the leveling instructions mentioned on page 38 in the outfeed adjustment instructions section. When both tables are coplanar and parallel to the cutterhead, you'll need to go back to page 19 and check the fence stops.



## TROUBLESHOOTING GUIDE (cont)

### INFEED / OUTFEED EXTENSION SUPPORT ADJUSTMENT

The infeed and outfeed extension supports are adjustable for coplanar or parallelism if ever necessary. These are set at the factory. If after planing or edge joining a work piece, an adjustment is necessary, follow these instructions.

1. On right hand side of jointer, place a straight edge on the infeed table alone across the infeed extension support and check for parallelism.
2. The straight edge should lay flat on the infeed table and the infeed extension support should just touch or leave a very small gap under the straight edge.
3. If adjustment is needed, loosen the extension lock nut (G) by hand, pull extension out about 5 inches, and retighten lock nut (G) Then, with the supplied wrench, loosen screws (A) and loosen set screws (B) in top of extension end bar. After completing the above, rotate the rod collars (C) to adjust the height of the end bar. Once correct height has been achieved, tighten the screws (A and B). Then recheck the parallelism. SEE FIG B

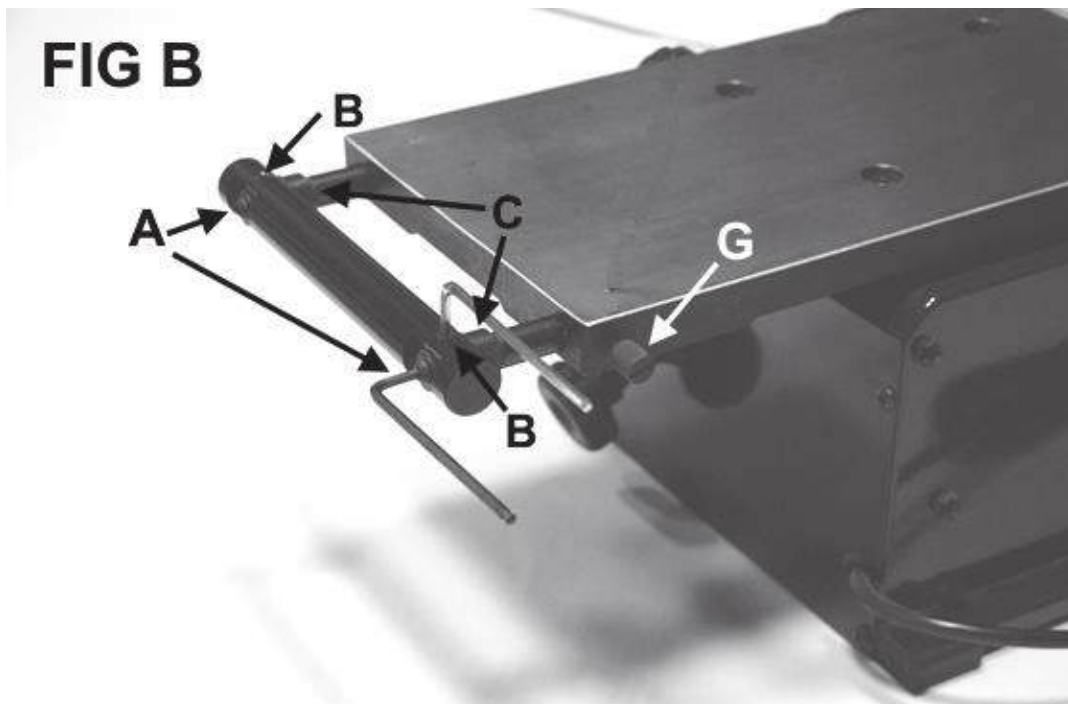

Do the same way for the infeed table on the right side of jointer. These adjustments, if necessary, may take a few attempts.

## TROUBLESHOOTING GUIDE (cont)

PROBLEM	LIKELY CAUSE	SOLUTION
Motor will not start.	Not plugged in. Blown circuit. Lockout key removed. Improper Voltage.	Check the power source. Replace fuse, reset breaker, or call electrician. Replace yellow safety key.
Fuses or circuit breaker blows.	Short circuit in line cord or plug. Unit overloaded.	Call electrician to repair or replace cord or plug for damaged insulation and shorted wires. Reduce load. Operate on circuit separate from other appliances or motors or connect to circuit with adequate amp rating.
Motor fails to develop full power	Power supply circuit overloaded with lights, appliances, and other motors. Undersized wires or too long.	Reduce load on circuit. Increase wire sizes or reduce length of the circuit.
Motor overheats.	Motor overloaded during operation. Air circulation through the motor restricted.	Reduce load on motor; take lighter cuts. Clean out motor to provide normal air circulation.
Motor stalls or shuts off during a cut.	Motor overloaded during operation. Short circuit in motor or loose connections. Circuit breaker tripped.	Reduce load on motor; take lighter cuts. Call electrician to repair or replace connections on motor for loose or shorted terminals or worn insulation. Install correct circuit breaker; reduce number of machines running on that circuit (circuit overload)
Blade slows when cutting or makes a squealing noise on start-up.	V-belt worn out. Dull cutter tips.	Replace V-belt.  Replace or rotate tips.

## TROUBLESHOOTING GUIDE (cont.)

PROBLEM	LIKELY CAUSE	SOLUTION
Vibration when operating jointer	Loose or damaged cutter tip. Damaged belt. Worn cutterhead bearing.	Tighten or replace knife. Replace belt Check/replace cutterhead bearing.
Infeed table hard to adjust	Table lock knob is engaged or partially engaged.	Completely loosen the table lock.
Work piece stops at the beginning of the cut.	Outfeed table is too high.	Align outfeed table with cutterhead tips .
Chipping or tear out	Knots or conflicting grain direction in wood. Nicked or chipped blades. Feeding work piece too fast Taking too deep of a cut.	Inspect work piece for knots and grain; only use clean stock. Rotate or replace knife. Slow down the feed rate. Take a smaller depth for cut(always reduce cutting depth when surface planing or working with hard woods) Slightly moisten wood before use
Fuzzy grain.	Wood may have high moisture content. Dull knives.	Check moisture content and allow to dry if moisture is too high. Replace knives.
Long lines or ridges that run along the length of the board.	Nicked, worn, or chipped knives.	Rotate or replace cutter tips.
Uneven cutter marks, wavy surface, or chatter marks across the face of the board.	Feeding work piece too fast Tips not even heights in the cutterhead.	Slow down the feed rate Clean cutterhead & tips so they are set evenly in the cutterhead.
Board edge is concave or convex after jointing	Board not held with even pressure on infeed and outfeed table during cut. Board has excessive bow or twist along its length. Tables not coplanar.	Hold board with even pressure as it moves over the cutterhead. Take partial cuts to remove the high spots before a full pass. Adjust tables for coplanar. It may take 3 to 5 passes to achieve a perfect edge depending on the condition of the board and the depth of cut.

# PARTS

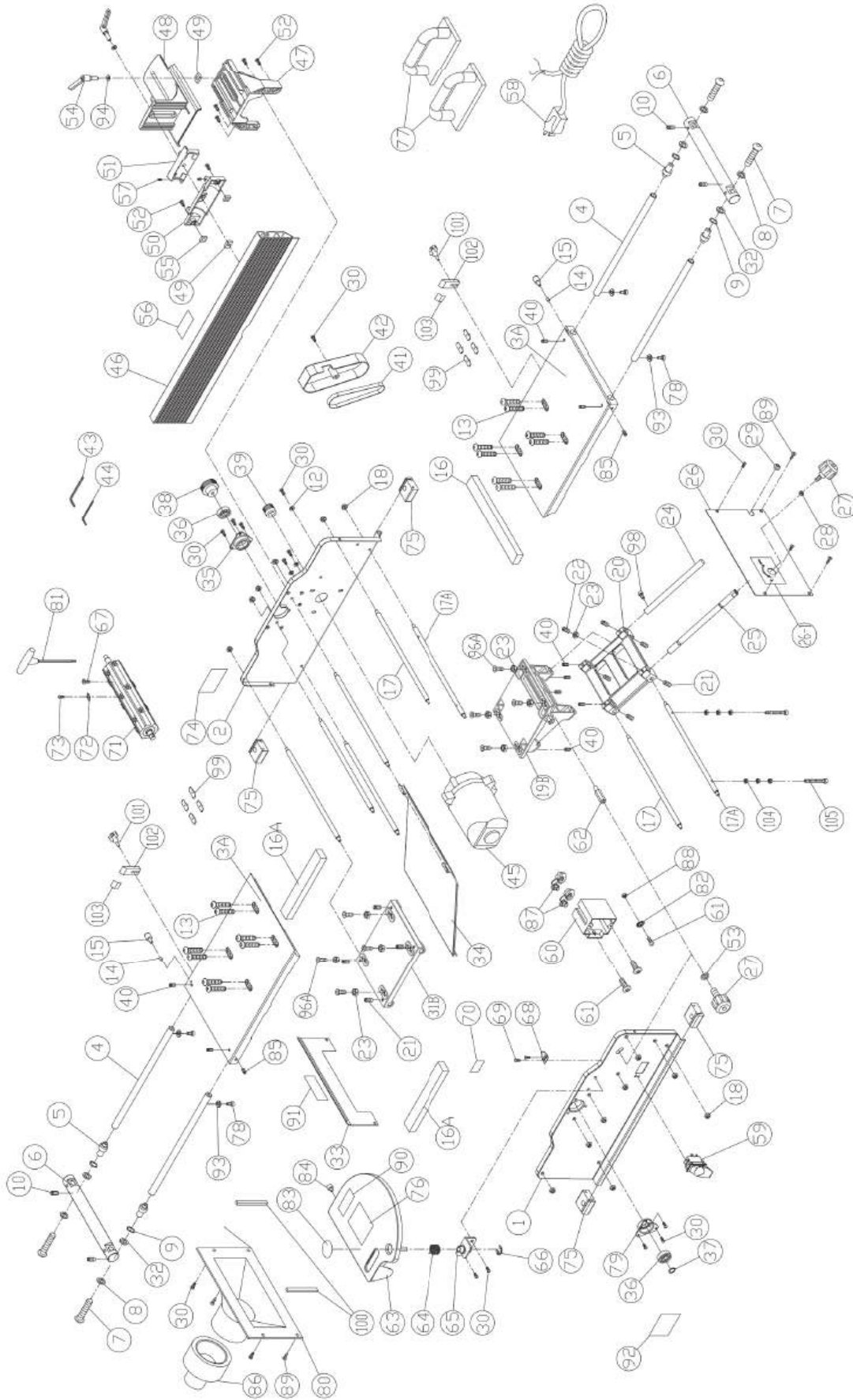

### Parts List

PART NO.	DESCRIPTION	SPECIFICATION	QTY
50110 1	Front Freame		1
50110 2	Rear Freame		1
50110 3A	Table		2
50110 4	Shaft		4
50110 5	Eccentric Sleeve		4
50110 6	Extend block		2
50110 7	Round Head Screw	M6x45	4
50110 8	Washer	M6	4
50110 9	Wave washer	WW14	4
50110 10	Set Screw	M8x6	4
50110 12	Washer	M6	3
50110 13	Round Head Screw	M6x30	16
50110 14	PU Block		2
50110 15	Fixed Screw	1/4"	2
50110 16	Foam Seal		1
50110 16A	Foam Seal		2
50110 17	Tie Rod		6
50110 17A	Tie Rod		2
50110 18	Hex Flange Nut	M6	16
50110 19B	Infeed Support		1
50110 20	Bracket		1
50110 21	Set Screw	M6x5	9
50110 22	Set Screw	M6x12	1
50110 23	Nut	M6	9
50110 24	Shaft		1
50110 25	Adjusting Rod		1
50110 26	Right cover		1
50110 26-1	Label		1
50110 27	Handle	M8x18	2
50110 28	Nut	M8	1
50110 29	Grommet		1
50110 30	Round Head Screw	M6x10	16
50110 31B	Outfeed Support		1
50110 32	Washer	M14	4
50110 33	Left Cover		1
50110 34	Dust Chute		1
50110 35	Bearing Retainer		1
50110 36	Bearing	6201	2
50110 37	C-Ring	S-12	1
50110 38	Drive Pulley		1
50110 39	Motor Pulley		1
50110 40	Set Screw (POM)	M6x6	9
50110 41	Belt	125J-5V	1
50110 42	Belt Guard		1

<b>PART NO.</b>	<b>DESCRIPTION</b>	<b>SPECIFICATION</b>	<b>QTY</b>
50110 43	Allen Key	4mm	1
50110 44	Allen Key	2.5mm	1
50110 45	Motor		1
50110 46	Fence		1
50110 47	Fence Bracket		1
50110 48	Fence Slide Bracket		1
50110 49	Special Nut	M8	2
50110 50	Bevel Bracket		1
50110 51	Intermediate Bracket		1
50110 52	Round Head Screw	M6x15	6
50110 53	Washer	M8-D18x2T	1
50110 54	Handle	M8x35	2
50110 55	Square Nut	M6	2
50110 56	Warning Label		1
50110 57	Set Screw	M5x10	2
50110 58	Power Cord		1
50110 59	Switch		1
50110 60	Switch Box		1
50110 61	Round Head Screw	#10-24UNC*1/2"	4
50110 62	Positioning Rod		1
50110 63	Guard ASSY		1
50110 64	Spring		1
50110 65	Bracket		1
50110 66	E-ring	ETW-8	1
50110 67	Flat head Screw	M5x15	4
50110 68	Pointer		1
50110 69	Round Head Screw	M4x6	2
50110 70	Depth Scale		1
50110 71	Spiral Cutterhead Assembly	10"	1
50110 71A	Pin		5
50110 72	Insert		20
50110 73	Torx Socket Head Cap Screw	M5x15	20
50110 74	I.D Label		1
50110 75	Foot		4
50110 76	Warning Label		1
50110 77	Push Block		2
50110 78	Round Head Screw	M6x6	4
50110 79	Bearing Retainer		1
50110 80	Dust Port		1
50110 81	Torx Wrench		1
50110 82	Tooth washer	M5	2

<b>PART NO.</b>	<b>DESCRIPTION</b>	<b>SPECIFICATION</b>	<b>QTY</b>
50110 83	Hole Plug		1
50110 84	Bumper Block		1
50110 85	Set Screw	1/4"-20UNC	2
50110 86	Dust collector adapter		1
50110 87	Strain Relief		2
50110 88	Nut	#10-24	2
50110 89	Tap Screw	1/4"-20UNCx3/4"	4
50110 90	Warning Label		1
50110 91	Warning Label		1
50110 92	Logo Label		1
50110 93	Spring Washer	M6	4
50110 94	Washer	M8-D23x2T	2
50110 96A	Set Screw	M6X16	8
50110 98	Cap screw	M6x10	1
50110 99	Cover for Table		8
50110 100	Foam	70*7*5	2
50110 101	Slot knob	M5x18	2
50110 102	baffle		2
50110 103	Foam		2
50110 104	Nut	M5	6
50110 105	Round Head Screw	M5x65	2

